

CONVIENT POUR VÉHICULE - APPROPRIATE FOR VEHICLE - VERWENDEN SIE FÜR FAHRZEUG -
 SERVE A VEICULO - CONVIENE PARA VEHICULO - PASUJENA SAMOCHOD -
 GESCHIKT VOOR VOERTUIG - APPROPRIARE PER VEICULE - MEGFELELŐ GÉPJÁRMŰ -
 ПОДХОДИТ ДЛЯ АВТОМОБИЛЕЙ - ΓΙΑ ΤΟ ΟΧΗΜΑ ΠΑΡΑ

						MM										MM									
						1	2	X	Y							1	2	X	Y						
ALFA ROMEO												LANCIA													
33	4/5 (1)	90→95	75	C		13	13	230	470	Delta						3	94→99	75	C	23	23	400	300		
AUDI												MAZDA													
100	4	91→94	75	C		21	20	285	410	626						5 (1)	98→	75	C	29	27	275	375		
100	4	83→90	75	C		14	10	255	440	626						5 (1)	92→97	75	C	19	14	200	400		
200	4	84→90	75	C		14	10	255	440	626						4	98→	75	C	29	27	275	375		
80 / 90	4	87→91	75	C		2	1	270	460	626						4	88→92	75	C	29	29	200	400		
A2	5	00→	50	C		29	23	270	330	MERCEDES															
A3 Sportback(2)	4	04→	60	C		25	17	210	480	190 (W 201)						4	83→93	75	C	31	26	300	400		
A 4	4	94→00	75	C		16	13	325	355	200/300 (W 124)						4	85→94	75	C	37	34	300	400		
A 4	4	01→	75	C		25	17	380	310	Classe A (W168)						5	98→08/04	75	C	26	16	250	400		
A 6	4	98→04/04	75	C		26	25	305	395	Classe C (W 202)						4	93→00	75	C	36	30	310	310		
A 6	4	05/2004→	75	C		33	33	310	400	Classe C (W 203)						4	00→	60	C	30	26	270	300		
A 6	4	94→97	75	C		21	20	285	410	Classe E (W 210)						4	96→01/02	75	C	38	38	350	350		
A 8	4	94→02	75	C		37	34	275	425	NISSAN															
BMW												Micra													
Série 3	4	98→02/05	75	C		23	20	290	360	Micra						5	93→02	50	C	2	2	265	335		
Série 5	4	96→06/03	75	C		26	22	260	400							5	03→	60	C	16	11	280	280		
Série 5	4	88→95	75	C		26	26	300	400	PEUGEOT															
Série 5	4	07/03→	60	C		34	34	245	470	605						4	90→99	75	C	29	29	260	440		
Série 7	4	95→11/01	75	C		33	33	300	400	607						4	00→	75	C	17	21	210	360		
CHEVROLET												RENAULT													
Evanda	4	05→	50	C		26	22	210	400	25						5	84→91	75	C	34	31	300	400		
Kalos	5	05→	60	C		21	14	300	400	Laguna						5 (1)	94→00	75	C	24	22	270	430		
Lacetti	4	05→	55	C		16	13	250	350	ROVER															
Matiz	5(2)	03/05→	50	C		5	5	320	330	25						5	00→	75	C	8	5	250	350		
DAEWOO												75						4	99→	75	C	27	28	230	340
Evanda	4	03→	50	C		26	22	210	400	Serie 200						5	96→00	70	C	8	5	250	350		
Kalos	5	02→	60	C		21	14	300	400	Serie 200						5	90→95	70	C	16	11	165	495		
Lacetti	4	04→	55	C		16	13	250	350	Serie 400						4	90→94	70	C	16	11	165	495		
Lanos	4,5	97→	75	B		22	20	300	350	Serie 600						4	93→99	75	C	15	15	260	380		
Leganza	4	97→	75	C		21	20	300	350	SEAT															
Nubira	4,5	97→06/03	75	B		27	27	300	350	Altea						5	04→	60	C	32	22	330	360		
FIAT												Cordoba						4	11/02→	60	C	13	10	295	370
Stilo	5	10/01→	75	C		33	29	80	550	Ibiza						3	03/02→	60	C	13	11	420	250		
FORD												Ibiza						5	03/02→	60	C	13	10	300	360
Fiesta	5	05/02→	75	C		29	27	170	430	Leon II						5	05→	60	C	36	25	325	360		
Fusion	5	09/02→	50 ESP	C		33	25	170	530	Toledo						5	10/04→	60	C	32	22	330	360		
Fusion	5	09/02→	25 ESP	C		33	25	170	530	SKODA															
HONDA												Favorit						5 (2)	88→95	75	C	9	9	250	450
Accord	4	93→98	75	C		16	12	300	350	Felicia						5 (2)	94→	75	C	9	9	250	450		
Accord	4	99→02	75	C		13	13	300	400	Forman						5 (2)	88→95	75	C	9	9	250	450		
Accord	4	03→	60	C		32	28	260	380	Superb						4	01→	75	C	29	27	280	510		
Civic	5	01→05	55	C		23	25	250	400	TOYOTA															
HYUNDAI												Avenis						5 (1)	98→04/03	70	C	16	12	290	390
Accent	5	00→06	75	C		14	13	295	385	Avenis						4	98→04/03	70	C	16	12	290	390		
Atos	5 (2)	98→	50	C		19	19	150	550	Avenis						4/5	05/03→	60	C	37	33	360	340		
Atos Prime	5	00→	50	C		21	21	250	450	Corolla						5 (1)	98→00	70	C	19	18	300	400		
Lantra/Elantra	5	00→	75	C		31	31	200	450	Starlet						5	96→	50	C	12	12	275	445		
Pony /Accent/Excell	4/5	95→00	75	C		6	2	250	350	VOLKSWAGEN															
Sonata	4	03/05→	60	C		40	40	260	380	Golf V						3	03→	60	C	35	21	510	190		
KIA												Golf V						5	03→	60	C	35	21	310	390
Picanto	5	03→	50	C		22	22	170	490	Golf V Plus						5	04→	60	C	32	23	330	360		
Magentis/Optima/Lotze	4	01→	55	C		36	33	300	350	Passat						4	89→96	75	C	15	7	265	450		
												Passat						4	97→02/05	75	C	28	28	285	405
												Passat						4	03/05→	60	C	36	36	240	430
												Polo						5	01/02→	75	C	20	15	80	560
												VOLVO													
												S40						4	04→	60	C	37	39	330	300

(1) Sauf break - Except station wagon/estate - Außer Kombi - Salvo break - Salvo break - Z wyjątkiem break - Behalve stationcars -
 Excerpto break - Kombit kivéve - За исключением автомобилей с кузовом "универсал" - Χωρίς break.

(2) Véhicule sans barres longitudinales d'origine - Vehicle without original longitudinal bars - Fahrzeuge ohne original-dachreling -
 Veicoli senza barre longitudinali originali - Vehículo sin barras longitudinales de origen - Samochód bez oryginalnych relingów -
 Voertuig zonder originele longitudinale stangen - Veículo sem barras longitudinais de origem - Gyárilag hosszirányú rudak nélkül
 szerelt gépjármű - Автомобиль без продольных дуг, предусмотренными моделью - Όχημα χωρίς διαμήκεις μπάρες από
 εργοστασιακή κατασκευή.

Instructions - Instructions - Anweisungen - Istruzioni - instrucciones -
 Instrukcje - Instructies - Instruções - Utasítások - Инструкция - Οδηγίες



SILVER Line KIT FIX 020

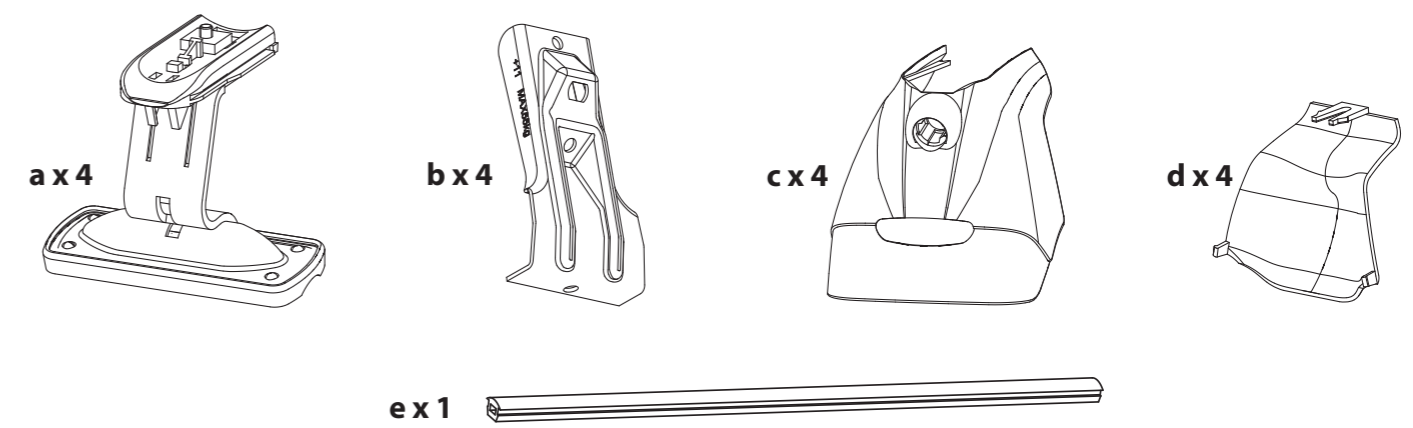

Fix Sabot - 036604

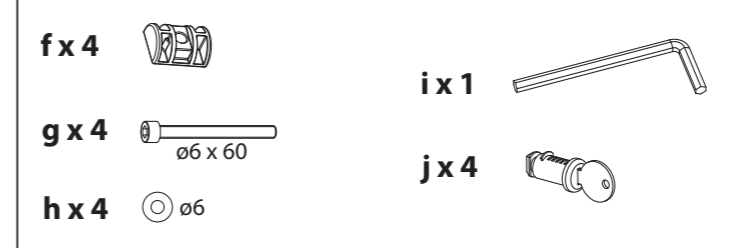

Fix Sabot - 036724



Voir liste d'affectation et réglages page 4 - See assignment list and adjustments, page 4 -
 Liste der Zuordnungen und Einstellungen siehe Seite 4 - Vedi elenco di destinazione e
 regolazione pag. 4 - Ver la lista de afectación y regulaciones en la página 4 - Patrz lista
 przydziału i ustawienia strona 4 - Zie lijst van modellen en instellingen pagina 4 - Ver a lista
 de atribuição e regulações na página 4 - Lásd a rendeltetések és beállítások listáját a 4.
 oldalon - Смотрите перечень автомобилей, с которыми совместим багажник, и
 раздел "Установка" на стр. 4 - Βλέπε τη λίστα των διορισμένων και τις ρυθμίσεις στη
 σελίδα 4.

- Garder cette notice pour les utilisations futures.
- Keep these instructions for future use.
- Die Anleitung zur späteren Benutzung aufbewahren.
- Conservare queste istruzioni per ogni ulteriore consultazione.
- Guardar este manual para futuras utilizaciones.
- Zachować instrukcję w przypadku użytkowania w przyszłości.
- Bewaar deze gebruiksaanwijzing voor toekomstige raadpleging.
- Guardar este manual para as utilizações futuras.
- Őrizze meg ezt a használati utasítást későbbi felhasználás céljából.
- Сохраните эту инструкцию для дальнейшего пользования.
- Φυλάξτε αυτό το εγχειρίδιο οδηγιών για μελλοντικές χρήσεις.



AUTOMAXI INTERNATIONAL
 Z.I Nord - 24 Rue Claude Bernard - CS 61768
 35417 Saint Malo Cedex - France
 Tél : 33 (0) 2 99 21 12 70
 Fax : 33 (0) 2 99 21 12 71
 www.automaxi.fr

